



CORDLESS PORTABLE PRESSURE WASHER – TOOL ONLY

48V MAX* | PRESSURE-SELECT TECHNOLOGY

1196 PSI MAX PRESSURE AT INITIAL DISCHARGE PER CSA INTERNAL PRESSURE TESTING

1 GPM MAX FLOW WITH NOZZLE OPEN AT MINIMUM PRESSURE

OPERATOR'S MANUAL

A Division of Snow Joe®, LLC

Model 24V-X2-PW1200-CT-RM

Form No. SJ-24V-X2-PW1200-CT-RM-880E-M-V1

THANKS FOR YOUR PURCHASE OF A REMANUFACTURED PRODUCT.

To make sure you get the most out of your product, be sure to register online at

[sunjoe.com](https://www.sunjoe.com)

to enjoy full product support.

PASTE UPC LABEL HERE



CORDLESS PORTABLE PRESSURE WASHER – TOOL ONLY

48V MAX* | PRESSURE-SELECT TECHNOLOGY

1196 PSI MAX PRESSURE AT INITIAL DISCHARGE PER CSA INTERNAL PRESSURE TESTING

1 GPM MAX FLOW WITH NOZZLE OPEN AT MINIMUM PRESSURE

OPERATOR'S MANUAL

A Division of Snow Joe®, LLC

Model 24V-X2-PW1200-CT-RM

Form No. SJ-24V-X2-PW1200-CT-RM-880E-M-V1

IMPORTANT! Safety Instructions

All Operators Must Read These Instructions Before Use

⚠️ WARNING! This indicates a hazardous situation, which, if not avoided, could result in death or serious injury.

⚠️ CAUTION! This indicates a hazardous situation, which, if not avoided, could result in minor or moderate injury.

⚠️ DANGER! This indicates a hazardous situation, which, if not followed, will result in death or serious injury.

General Safety

⚠️ WARNING! This appliance is not intended for use by persons (including children) with reduced physical, sensory or mental capabilities, or lack of experience and knowledge, unless they have been given supervision or instruction concerning use of the appliance by a person responsible for their safety.

Children should be supervised to ensure that they do not play with the appliance.

Before starting up your machine, please check it carefully for any defects. If you find any, do not start up your machine. Contact your authorized Snow Joe® + Sun Joe® dealer or call the Snow Joe® + Sun Joe® customer service center at 1-866-SNOWJOE (1-866-766-9563).

⚠️ WARNING! When using the pressure washer, basic safety precautions should always be followed to reduce the risk of fire, electric shock, and personal injury. These include:

- **Know your product** – Know how to stop the machine and bleed pressure quickly. Thoroughly familiarize yourself with the controls.
- **Keep bystanders away** – All visitors and pets should be kept a safe distance away from the work area.
- **Use the right product** – Do not use this machine for any job except that for which it is intended.
- **Dress properly** – Do not wear loose clothing or jewelry. They can get caught in moving parts. Protective rubber gloves and non-slip footwear are recommended when working outdoors.

- **⚠️ CAUTION!** – Exercise caution to avoid slipping or falling. Wear protective footwear that will protect your feet and improve your footing on slippery surfaces.
- **Stay alert** – Watch what you are doing. Use common sense. Do not operate the pressure washer when you are tired, or under the influence of alcohol or drugs.
- **Do not overreach** – Keep proper footing and balance at all times.
- **Avoid unintentional starting** – Do not carry a machine with power with your finger on the trigger. Make sure the switch is off before insert the batteries.
- **Remove the batteries** – Remove the batteries from the pressure washer when it is not in use, before servicing it, when changing accessories, and when performing any other maintenance task.
- **Use safety glasses** – Also use safety footwear, snug-fitting clothing, protective gloves, hearing and head protection.
- **Check the water temperature** – This pressure washer is not meant to pump hot water. **NEVER** connect it to a hot water supply or pour hot water into the bucket as it will significantly reduce the life of the pump.
- **Store indoors** – **NEVER** store the pressure washer outdoors or where it could freeze. The pump could be seriously damaged.

⚠️ WARNING! Do not use this appliance without reading this instruction manual.

⚠️ WARNING! This appliance has been designed for use with cleaning agents that are recommended by the manufacturer. The use of other cleaning agents or chemicals may adversely affect the safety of the appliance.

⚠️ WARNING! Do not use the appliance within range of persons unless they are wearing protective clothing.

⚠️ WARNING! High-pressure jets can be dangerous if subject to misuse. The jet must not be directed at persons, pets, live electrical equipment, or the appliance itself.

- Do not direct the jet at yourself or others in order to clean clothes or footwear.
- **Risk of explosion** – Do not spray flammable liquids.
- **Keep children away** – This cordless pressure washer must not be used by children or untrained personnel. Close supervision is necessary when a product is used near children.

- To ensure appliance safety, use only original replacement parts from the manufacturer or those approved by the manufacturer.

⚠️ WARNING! During cleaning, maintenance or when replacing parts, the machine must be disconnected from its power source by removing the batteries.

⚠️ WARNING! High-pressure hoses, fittings, and couplings are important for the safe operation of the appliance. Use only hoses, fittings, and couplings recommended by the manufacturer.

⚠️ WARNING! Electrical Shock Hazard – Before starting up your machine, please check it carefully for any defects. If you find any, do not start up your machine and contact your distributor.

IMPORTANT: Only use water without any impurities. If there is a risk of running sand into the inlet water (i.e. from your own well), an additional filter should be installed.

- **Check for damaged parts** – Do not use the appliance if any important parts of the appliance are damaged (e.g. safety devices, high-pressure hoses, trigger gun).
- This cordless pressure power washer must not be used at temperatures below 32°F (0°C).
- Keep the machine on a stable, flat surface during operation, handling, transportation, and storage. Sudden overturn of the machine can cause bodily injury.
- In the event of an accident or breakdown, switch off the machine immediately (If contact with detergent occurs, rinse with an abundance of clean water).

Battery + Charger Safety Instructions

NOTE: This unit is tool only. The batteries and the charger are not included. They must be purchased separately.

Model 24V-X2-PW1200-CT-RM is compatible with the iON+ 24V System batteries and chargers. See page 21 for more information.

We pay a great deal of attention to the design of every battery pack to ensure that we supply you with batteries that are safe, durable and have a high energy density. The battery cells have a wide range of safety devices. Each individual cell is initially formatted and its electrical characteristic curves are recorded. This data is then used exclusively to be able to assemble the best possible battery packs.

Despite all the safety precautions, caution must always be exercised when handling the batteries. The following points must be obeyed at all times to ensure safe use. Safe use can only be guaranteed if undamaged cells are used. Incorrect handling of the battery pack can cause cell damage.

IMPORTANT! Analyses confirm that incorrect use and poor care of high-performance batteries are the main factors responsible for personal and/or product damage.

⚠️ WARNING! Use only approved replacement batteries; other batteries may damage the cordless pressure washer and cause it to malfunction, which can lead to serious personal injury.

⚠️ WARNING! Do not use a battery pack or appliance that is damaged or modified. Damaged or modified battery may exhibit unpredictable behavior resulting in fire, explosion or risk of injury.

Do not modify or attempt to repair the appliance or the battery packs except as indicated in the instructions for use and care.

Have your battery packs serviced by a qualified repair person using only identical replacement parts. This will ensure that the safety of the battery packs is maintained.

⚠️ CAUTION! To reduce the risk of injury, charge the iON+ 24V lithium-ion battery packs only in the designated iON+ 24V lithium-ion charger. Other types of chargers present risk of fire, personal injury and damage. Do not wire the battery packs to a power supply plug or car cigarette lighter. Such misuse will permanently disable or damage the battery packs.

- **Avoid dangerous environments** – Do not charge the battery packs in rain, snow or in damp or wet locations. Do not use the battery packs or charger in the presence of explosive atmospheres (gaseous fumes, dust or flammable materials) because sparks may be generated when connecting or disconnecting the battery pack, which could lead to a fire.
- **Charge in a well-ventilated area** – Do not block the charger vents. Keep them clear to allow for proper ventilation. Do not allow smoking or open flames near a charging battery pack. Vented gases may explode.

NOTE: The safe temperature range for the battery is 41°F – 105°F (5°C – 40.5°C). Do not charge the batteries outside in freezing weather; charge it at room temperature.

- **Maintain charger cord** – When unplugging the charger, pull the plug, not the cord, from the receptacle to reduce the risk of damage to the electrical plug and cord. Never carry the charger by its cord or yank it by the cord to disconnect it from the receptacle. Keep the cord away from heat, oil and sharp edges. Make sure the cord will not be stepped on, tripped over or subjected to damage or stress when the charger is in use. Do not use the charger with a damaged cord or plug. Replace a damaged charger immediately.
- **Do not use an extension cord unless it is absolutely necessary** – Using the wrong, damaged or improperly wired extension cord poses a risk of fire and electric shock. If an extension cord must be used, plug the charger into a properly wired 16 gauge or larger extension cord with the female plug matching the male plug on the charger. Make sure that the extension cord is in good electrical condition.

- **Use only recommended attachments** – Use of an attachment not recommended or sold by the battery charger or battery pack manufacturer may result in risk of fire, electric shock or personal injury.
- **Unplug charger when not in use** – Make sure to disconnect battery packs from unplugged charger.

⚠️ WARNING! To reduce the risk of electric shock, always unplug the charger before performing any cleaning or maintenance. Do not allow water to flow into the charger. Use a Ground Fault Circuit Interrupter (GFCI) to reduce shock hazards.

- **Do not burn or incinerate battery packs** – Battery packs may explode, causing personal injury or damage. Toxic fumes and materials are created when the battery pack is burned.
- **Do not crush, drop or damage battery packs** – Do not use the battery packs or charger if they have sustained a sharp blow, been dropped, run over or have been damaged in any way (i.e. pierced with a nail, hit with a hammer, stepped on, etc.).
- **Do not disassemble** – Incorrect reassembly may pose a serious risk of electric shock, fire or exposure to toxic battery chemicals. If the batteries or charger are damaged, contact an authorized Snow Joe® + Sun Joe® dealer or call the Snow Joe® + Sun Joe® customer service center at 1-866-SNOWJOE (1-866-766-9563) for assistance.
- **Battery chemicals cause serious burns** – Never let a damaged battery pack contact the skin, eyes or mouth. If a damaged battery pack leaks battery chemicals, use rubber or neoprene gloves to safely dispose of it. If skin is exposed to battery fluids, wash the affected area with soap and water and rinse with vinegar. If eyes are exposed to battery chemicals, immediately flush with water for 20 minutes and seek medical attention. Remove and dispose of contaminated clothing.
- **Do not short circuit** – A battery pack will short circuit if a metal object makes a connection between the positive and negative contacts on the battery pack. Do not place a battery pack near anything that may cause a short circuit, such as paper clips, coins, keys, screws, nails and other metallic objects. A short-circuited battery pack poses a risk of fire and severe personal injury.
- **Store your battery packs and charger in a cool, dry place** – Do not store the battery packs or charger where temperatures may exceed 105°F (40.5°C), such as in direct sunlight or inside a vehicle or metal building during the summer.

Information about the batteries

1. For optimum battery performance, avoid low discharge cycles by charging the battery packs frequently.
2. Store the battery packs in a cool place, ideally at 77°F (25°C) and charged to at least 40%.
3. Lithium-ion batteries are subject to a natural aging process. The battery packs must be replaced at the latest

when their capacity falls to just 80% of its capacity when new. Weakened cells in an aged battery pack are no longer capable of meeting the high power requirements needed for the proper operation of your cordless pressure washer, and therefore pose a safety risk.

4. Do not throw the battery packs into an open fire as this poses a risk of explosion.
5. Do not ignite the battery packs or expose them to fire.
6. Do not exhaustively discharge the batteries. Exhaustive discharge will damage the battery cells. The most common cause of exhaustive discharge is lengthy storage or non-use of partially discharged battery. Stop working as soon as the performance of the battery fall noticeably or the electronic protection system triggers. Place the battery packs in storage only after they have been fully charged.
7. Protect the batteries and the tool from overloads. Overloads will quickly result in overheating and cell damage inside the battery housing even if this overheating is not apparent externally.
8. Avoid damage and shocks. Immediately replace the batteries that has been dropped from a height of more than one meter or has been exposed to violent shocks, even if the housing of the battery pack appears to be undamaged. The battery cells inside the battery may have suffered serious damage. In such instances, please read the waste disposal information for proper battery disposal.
9. If the battery packs suffer overloading and overheating, the integrated protective cutoff will switch off the equipment for safety reasons.
IMPORTANT! Do not press the On/Off button any more if the protective cut-off has been activated. This may damage the battery packs.
10. Use only original battery packs. The use of other batteries poses a fire risk and may result in injuries or an explosion.

Information about the charger and the charging process

1. Please check the data marked on the rating plate of the battery charger. Be sure to connect the battery charger to a power supply with the voltage marked on the rating plate. Never connect it to a different mains voltage.
2. Protect the battery charger and its cord from damage. Keep the charger and its cord away from heat, oil and sharp edges. Have damaged cords repaired without delay by a qualified technician at an authorized Snow Joe® + Sun Joe® dealer or call the Snow Joe® + Sun Joe® customer service center at 1-866-SNOWJOE (1-866-766-9563).
3. Electrical plugs must match the outlet. Never modify the plug in any way. Do not use any adapter plugs with grounded appliances. Unmodified plugs and matching outlets will reduce the risk of electric shock.
4. Keep the battery charger, battery packs and the cordless tool out of the reach of children.

5. During periods of heavy use, the battery packs will become warm. Allow the battery packs to cool to room temperature before recharging.
6. Do not overcharge the batteries. Do not exceed the maximum charging times. These charging times only apply to discharged batteries. Frequent connection of a charged or partially charged battery pack will result in overcharging and cell damage. Do not leave the batteries connected with the charger for days on end.
7. Never use or charge battery if you suspect that it has been more than 12 months since the last time they were charged. There is a high probability that the battery pack has already suffered dangerous damage (exhaustive discharge).
8. Charging the batteries at a temperature below 41°F (5°C) will cause chemical damage to the cells and may cause a fire.
9. Do not use batteries that have been exposed to heat during the charging process, as the battery cells may have suffered dangerous damage.
10. Do not use the battery if it suffered curvature or deformation during the charging process or exhibit other atypical symptoms (gassing, hissing, cracking, etc.).
11. Never fully discharge the battery packs (maximum recommended depth of discharge is 80%). A complete discharge of the battery pack will lead to premature aging of the battery cells.

Protection from environmental influences

1. Wear suitable work clothes. Wear safety goggles.
2. Protect your cordless tool and the battery charger from moisture and rain – Moisture and rain can cause dangerous cell damage.
3. Do not use the cordless tool or the battery charger near vapors and flammable liquids.
4. Use the battery charger and cordless tools only in dry conditions and at an ambient temperature of 41°F – 105°F (5°C – 40.5°C).
5. Do not keep the battery charger in places where the temperature is liable to reach over 105°F (40.5°C). In particular, do not leave the battery charger in a car that is parked in the sunshine.
6. Protect batteries from overheating. Overloads, overcharging and exposure to direct sunlight will result in overheating and cell damage. Never charge or work with batteries that have been overheated – replace them immediately, if possible.
7. Store the charger and your cordless tool only in dry locations with an ambient temperature of 41°F – 105°F (5°C – 40.5°C). Store your lithium-ion battery packs in a cool, dry place at a temperature of 77°F (25°C). Protect the battery packs, charger and cordless tool from humidity and direct sunlight. Only place fully charged batteries in storage (charged to at least 40%).
8. Prevent the lithium-ion battery packs from freezing. Battery packs that were stored below 32°F (0°C) for more than 60 minutes must be discarded.

9. When handling the batteries, be wary of electrostatic charge. Electrostatic discharges can damage the electronic protection system and the battery cells. Avoid electrostatic charging and never touch the battery poles.

Risk of Explosion

- Do not spray flammable liquids.
- Do not use acids, bases, solvents, or any flammable material in this product. These substances can cause physical injuries to the operator and irreversible damage to the machine.

Additional Safety Instructions

- High-pressure: keep clear of nozzle.
- Injection hazard: equipment can cause serious injury if the spray penetrates the skin.
- Do not point the gun at anyone or at any part of the body.
- In case of skin penetration, seek medical aid immediately.
- Before servicing, cleaning, or removing any parts, shut off the power and relieve pressure.
- This machine is not suitable for connection to the potable water mains.
- Do not spray electrical apparatus and wiring.
- **ARCING PARTS** – Keep the motor at least 20 ft (6 m) away from explosive vapors.
- **⚠CAUTION!** Gun kicks back. Hold trigger with both hands.

Product Description

Purpose











- This cordless pressure power washer is intended for residential use to clean vehicles, machines, buildings, facades, etc.

Areas of Application

- Never use the machine in potentially explosive areas under any circumstances!
- The operating temperature must be between 32°F (0°C) and 104°F (40°C).
- The machine consists of an assembly with a pump, which is encased in a shock-absorbing housing. To provide the operator with an optimal working position, the machine is equipped with a spray wand.
- Do not cover or modify the spray wand or the spray nozzles in any way.
- The cordless pressure washer is designed to be used with cold or lukewarm water; higher temperatures can damage the pump.
- Do not use water that is dirty, gritty, or contains any chemical products, as these could impair operation and shorten the life of the machine.

Safety Symbols

The following table depicts and describes safety symbols that may appear on this product. Read, understand, and follow all instructions on the machine before attempting to assemble and operate.

Symbols	Descriptions	Symbols	Descriptions
	READ THE OPERATOR'S MANUAL(S) – Read, understand, and follow all instructions in the user manual(s) before attempting to assemble and operate.		SAFETY ALERT – Indicates a precaution, a warning, or a danger.
	WARNING! Do not expose the unit to rain or wet conditions. Keep dry.		WEAR EYE AND HEARING PROTECTION – For protection against injury, wear ear defenders and safety goggles.
	To reduce the risk of injury, user must keep all bystanders at least 49 ft (15 m) away.		Machine not suitable for connection to the potable water mains.
	Wear safety gloves during use to protect hands.		Wear non-slip footwear that will protect your feet and improve your footing on slippery surfaces.
	Store indoors. Never store the pressure washer outdoors. If the pump freezes, permanent damage may result.		Indoor use only. Only use battery charger indoors.

Know Your Cordless Pressure Washer

Read the owner's manual and safety instructions carefully before operating the cordless pressure washer. Compare the illustration below to the cordless pressure washer in order to familiarize yourself with the location of the various controls and adjustments. Save this manual for future reference.

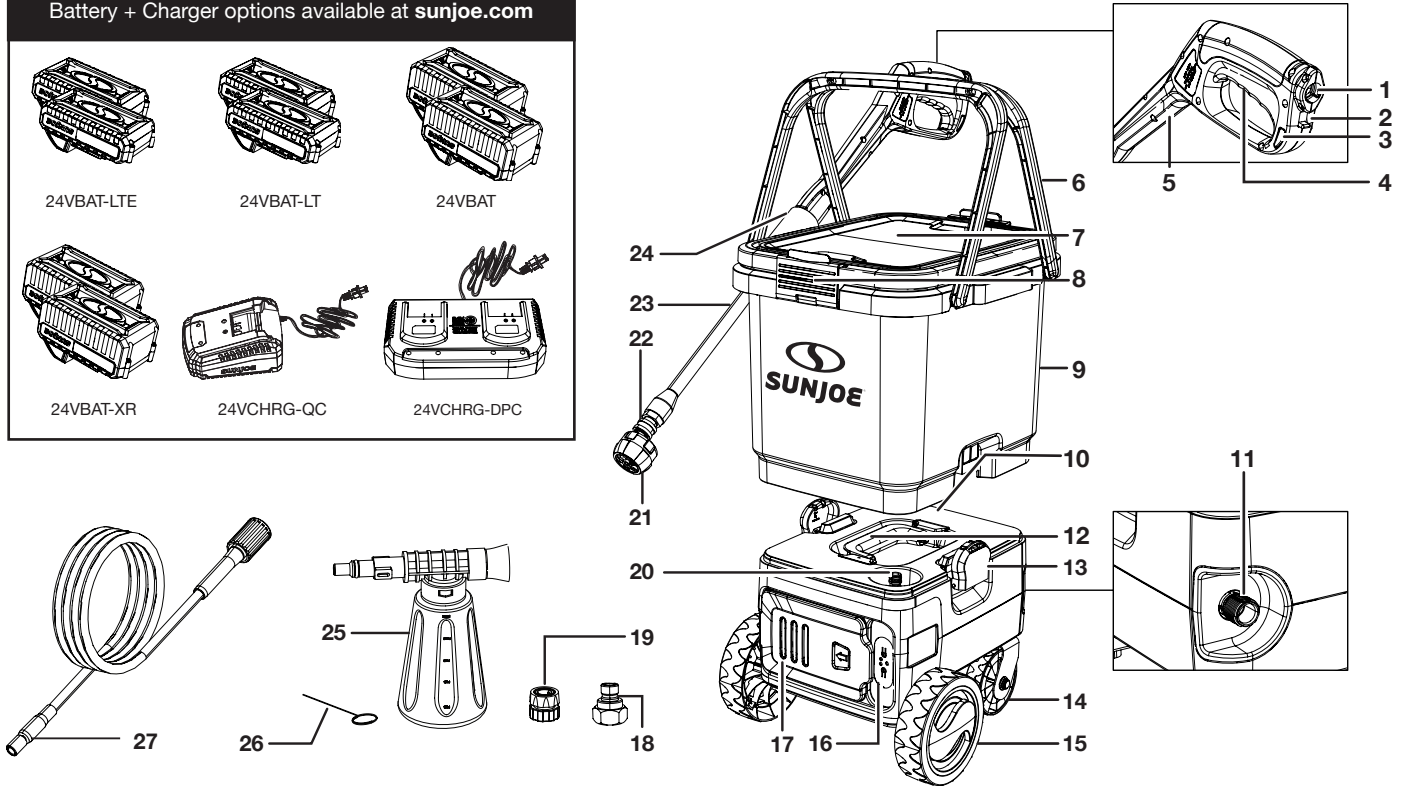
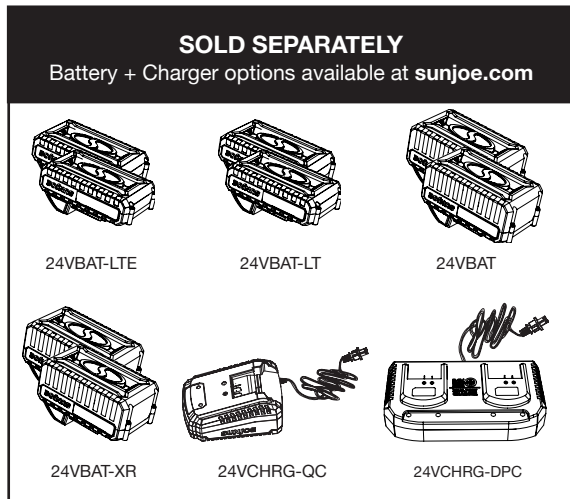

- | | | |
|----------------------------------|------------------------------------------------|---------------------------------|
| 1. High-pressure hose connection | 11. Water outlet/high-pressure hose connection | 20. Water inlet/Bucket adapter |
| 2. Lock latch | 12. Base handle | 21. 5-in-1 Quick-Connect nozzle |
| 3. Safety lock | 13. Bucket buckles (2) | 22. Quick-Connect collar |
| 4. Trigger | 14. All-direction wheel (2) | 23. Spray wand |
| 5. Trigger gun | 15. Front wheel | 24. Trigger gun holder |
| 6. Bucket handles (2) | 16. Control panel | 25. Foam Cannon |
| 7. Bucket lid | 17. Battery compartment cover | 26. Needle clean-out tool |
| 8. Lid buckles (2) | 18. Water inlet connector | 27. High-pressure hose |
| 9. Water bucket | 19. Garden hose adapter/connection | |
| 10. Base unit | | |

Technical Data

Motor	600 W Brushless
Battery Voltage Max*	48V D.C. (2 x 24 V)
Max Water Inlet Temperature	104°F/40°C
Max Water Inlet Pressure	0.7 MPa
Max Pressure at initial discharge	1196 PSI
per CSA internal pressure testing	
Rated Pressure under typical load	LOW 650 PSI
	HIGH 800 PSI
Max Flow with nozzle open	1 GPM
at minimum pressure	
Rated Flow under typical load	LOW 0.65 GPM
	HIGH 0.77 GPM
Removable Bucket Capacity	6.6 gal (25 L)
Foam Cannon Capacity	8.5 fl oz (0.25 L)
High Pressure Hose Length	20 ft (6 m)
Net Weight	21 lbs (9.5 kg)

* Generates 48 V max with two 24 V lithium-ion batteries. Initial no-load voltage, per fully charged battery, peaks at 24 V. Nominal voltage under typical load is 21.6 V.

Unpacking

Carton Contents

- Water bucket assembly
 - Bucket lid
 - Base unit
 - Trigger gun
 - Spray wand
 - 5-in-1 Quick-Connect nozzle
 - Needle clean-out tool
 - Foam cannon
 - Trigger gun holder
 - High-pressure hose
 - Garden hose adapter (female coupler)
 - Water inlet connector
 - Manuals and registration card
1. Carefully remove the pressure washer and check to see that all of the above items are supplied.
 2. Inspect the product carefully to make sure no breakage or damage occurred during shipping. If you find damaged or missing parts, DO NOT return the unit to the store. Please call the Snow Joe® + Sun Joe® customer service center at 1-866-SNOWJOE (1-866-766-9563).

NOTE: Do not discard the shipping carton and packaging material until you are ready to use your new cordless pressure washer. The packaging is made of recyclable materials. Properly dispose of these materials in accordance with local regulations.

IMPORTANT! The equipment and packaging material are not toys. Do not let children play with plastic bags, foils, or small parts. These items can be swallowed and pose a suffocation risk!

⚠ WARNING! Do not insert the batteries until assembly is complete. Failure to comply could result in accidental starting and possible serious personal injury.

Battery Pack Operation

The equipment is powered by 2 lithium-ion batteries. The battery packs are completely sealed and maintenance free.

TOOL ONLY

BATTERY + CHARGER SOLD SEPARATELY





In order to operate this cordless pressure washer you will need two batteries and one charger from the iON+ 24V System. See page 21 for battery and charger options and specifications, or for more information visit sunjoe.com.

⚠ WARNING! The pressure washer can only be powered by both of the batteries together. Using one battery cannot provide sufficient power to start the tool. Make sure to use two batteries of the same voltage and the same capacity. Using the tool with batteries of different capacities will cause damage to the batteries.

Battery Charge Level Indicator

The battery packs are equipped with a push button for checking the charge level. Simply press the push button to read off the battery charge level from the LEDs of the battery indicator:

- All 3 level monitoring LEDs are lit: Battery charge level is high.
- 2 level monitoring LEDs are lit: Battery charge level is decreasing. Stop work as soon as possible.
- 1 level monitoring LED is lit: Battery is flat. Stop work IMMEDIATELY and charge the battery. Otherwise the battery's service life will be greatly shortened.

Lights	Light Indicators
	Charge level button
	The battery is at 30% capacity and requires charging
	The battery is at 60% capacity and requires charging soon
	The battery is at full capacity

NOTE: If the charge level button does not appear to be working, connect to the charger and charge as needed.

NOTE: Immediately after using the battery packs, the charge level button may display a lower charge than it will if checked a few minutes later. The battery cells "recover" some of their charge after resting.

Charger Operation

TOOL ONLY

BATTERY + CHARGER SOLD SEPARATELY

In order to operate this cordless pressure washer you will need two batteries and one charger from the iON+ 24V System. See page 21 for battery and charger options and specifications, or for more information visit sunjoe.com.

⚠ WARNING! Charge only iON+ 24V lithium-ion battery packs with its compatible iON+ 24V lithium-ion charger. Other types of batteries may cause personal injury and damage.

To reduce the risk of electric shock, do not allow water to flow into the charger's AC/DC plug.

When to Charge the iON+ 24V Lithium-iON Battery

NOTE: The iON+ 24V lithium-iON battery packs do not develop a "memory" when charged after only a partial discharge. Therefore, it is not necessary to run down the battery packs before charging them again.

- Use the battery indicator lights to determine when to charge your iON+ 24V lithium-iON battery packs.
- You can "top-off" your battery packs' charge before starting a big job or after a long day of use.

Charging the Battery

1. Open the battery compartment cover, and push the push lock buttons on the batteries to pull the battery packs out from the battery compartment (Fig. 1).

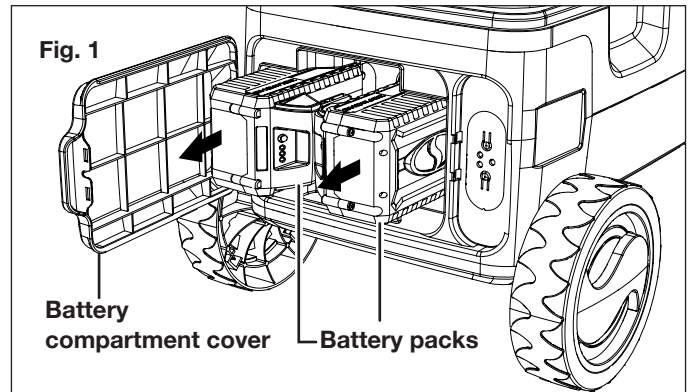

2. Depending on your Snow Joe® + Sun Joe® charger model, how to recharge your lithium-ion batteries will vary. You may either insert your 24-volt batteries into the 24VCHRG-QC Quick Charger (sold separately) or the 24VCHRG-DPC Dual Port Charger (sold separately) (Figs. 2 – 3).

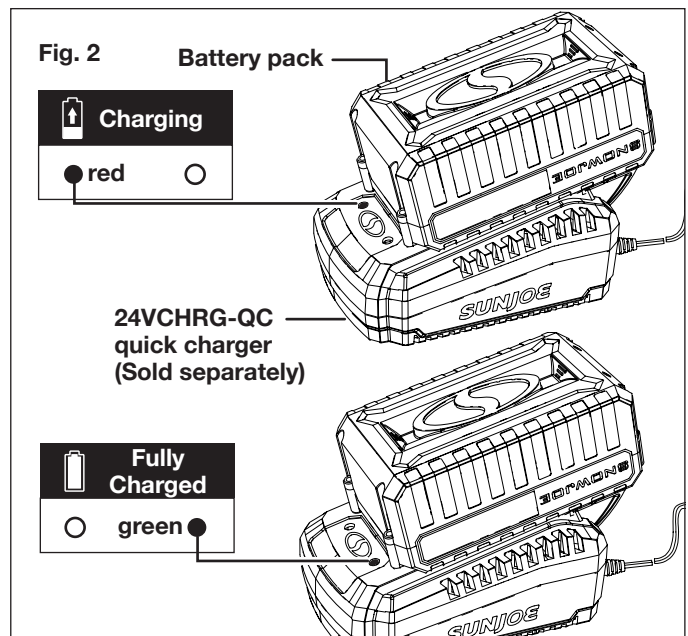

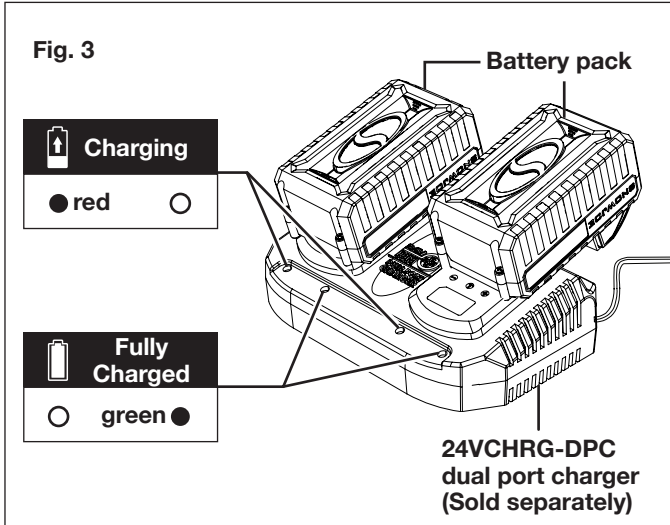

3. The battery indicator LEDs will illuminate one by one during the charging process. Unplug the charger immediately when the 3 LEDs are all illuminated.
4. The 24VCHRG-QC Quick Charger (sold separately) and the 24VCHRG-DPC Dual Port Charger (sold separately) are also equipped with additional charging indicating lights which will indicate the charging status (Figs. 2 – 3).

⚠ CAUTION! FIRE HAZARD. When removing the batteries from the charger, be sure to unplug the charger from the outlet first, then remove the batteries from the charger.

⚠ WARNING! This charger does not automatically turn off when the batteries are fully charged. Please take care not to leave the batteries in the charger. Switch off or unplug the charger at the mains when charging is complete.

5. Timely recharging of the batteries will help prolong the batteries' life. You must recharge the battery packs when you notice a drop in the equipment's power.

IMPORTANT! Never allow the battery packs to become fully discharged as this will cause irreversible damage to the batteries.

6. When charging is complete, remove the batteries from the charger by pulling the push lock button and sliding the batteries backward to unlock it from the charger.

Assembly

1. The washer must be used on a secure and stable surface in a standing, upright position (Fig. 4).



2. Open the box, take out the bucket lid, bucket and the base unit (Fig. 5).

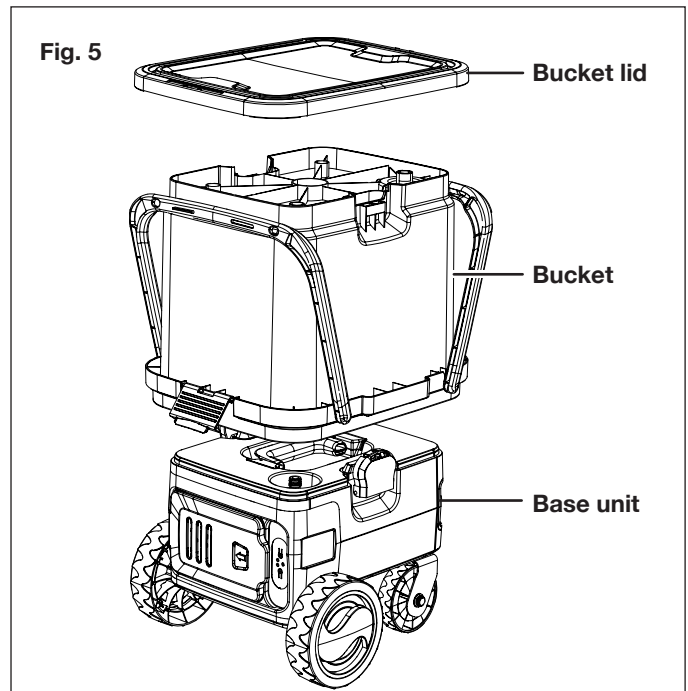

3. Insert the trigger gun holder onto the bucket (Fig. 6).

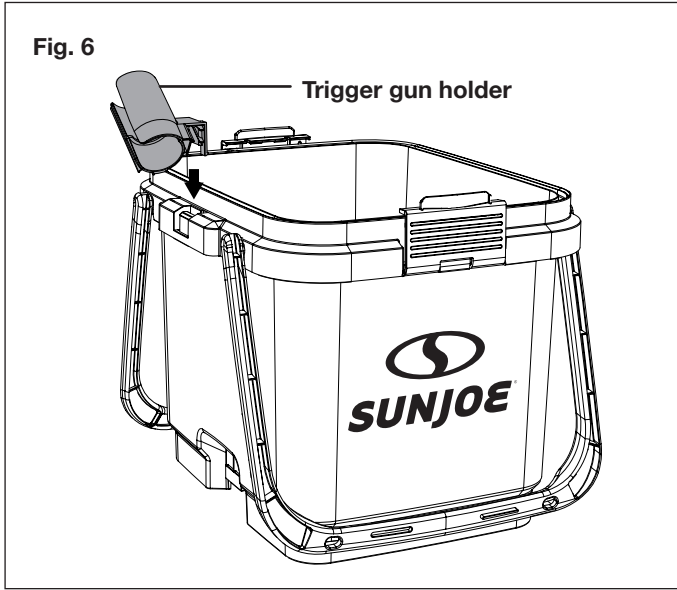

4. Align the water inlet on the base unit with the outlet on the bottom of the bucket, and seat the bucket on the base unit. Check alignment to ensure a proper seal and connection (Fig. 7).

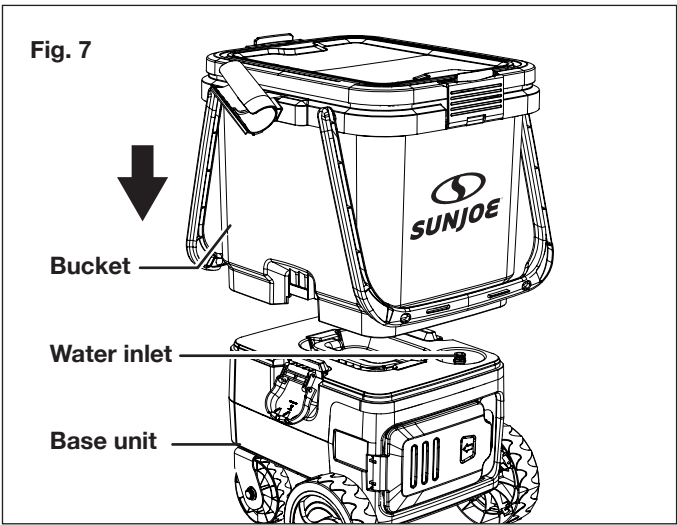

5. Flip up the buckles on the base unit and latch to bucket. Press down on the buckle ends to lock the bucket to the base unit (Fig. 8).

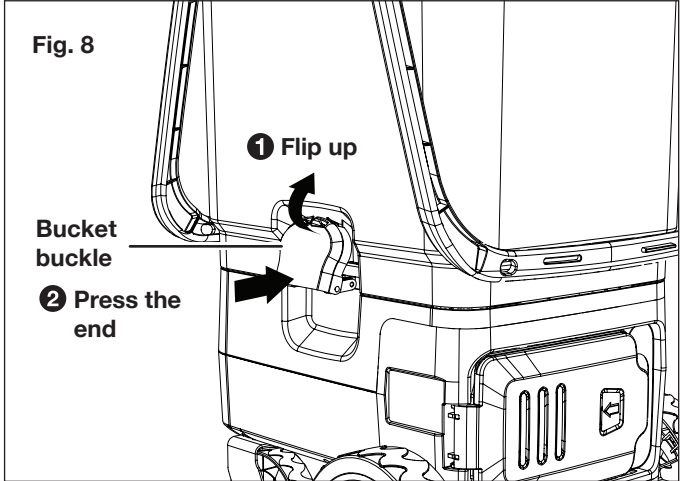

⚠ WARNING! When the water bucket is fixed on the base unit, do not lift the pressure washer by the handles. Instead, use the one handle to pull the pressure washer unit along on its wheels (Fig. 9).

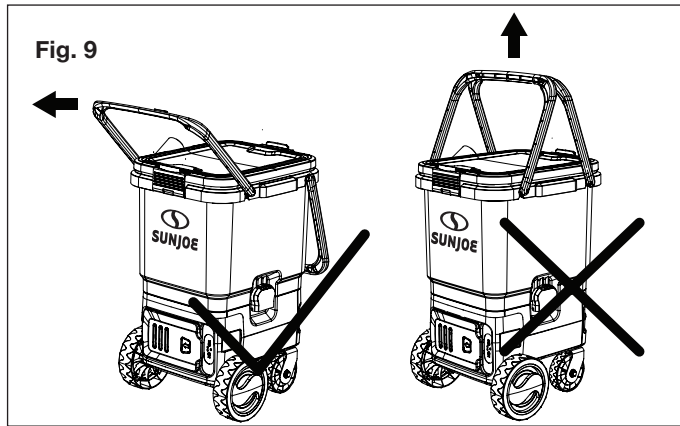

6. Take the spray wand and align the two tabs with your trigger gun. Once aligned, push the spray wand firmly into the trigger gun, twist counter-clockwise to lock into place (Fig. 10).

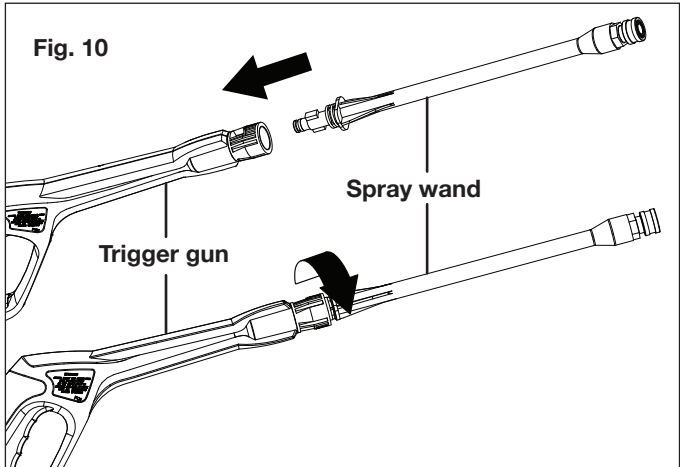

7. The 5-in-1 nozzle is equipped with a Quick-Connect tip which can be easily attached to the Quick-Connect collar of the spray wand. To connect the nozzle, pulling the quick-connect collar backwards, at the same time, snap the nozzle onto the quick-connect collar until it *clicks* into place, then release the quick-connect collar (Fig. 11).

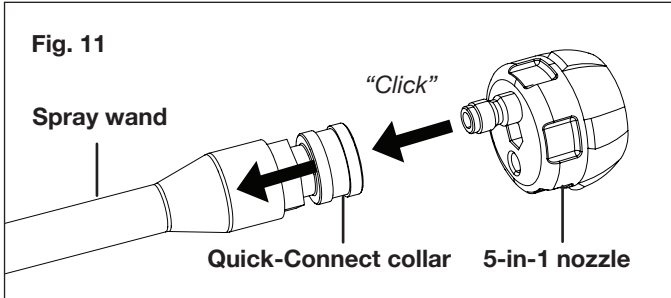

⚠️ WARNING! Do not attach or remove the nozzle while the trigger is engaged. Doing so could result in damage to the pressure washer or injury to the user.

8. Unlock the lock latch by sliding it down, and insert the high pressure hose into the high pressure hose connection on the end of the trigger gun. Slide the latch back to lock the hose in place (Figs. 12 – 13).

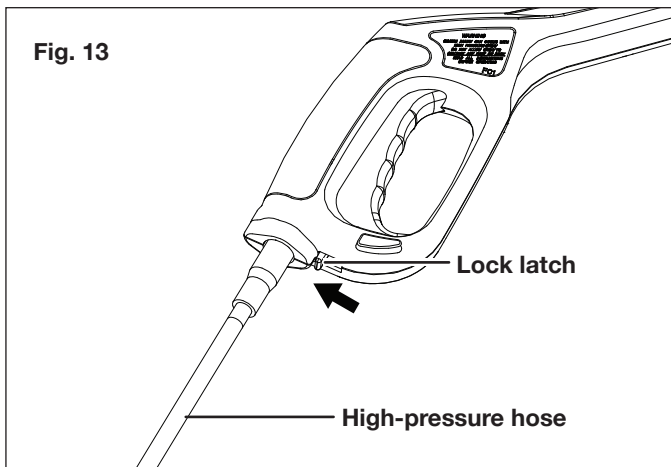
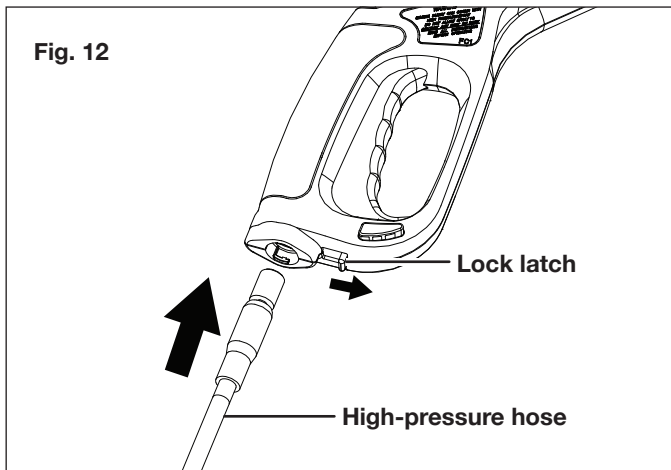

⚠️ WARNING! Keep hose away from sharp objects. Bursting hoses may cause injury. Examine hoses regularly and replace if damaged. Do not attempt to mend a damaged hose.

9. Connect the high-pressure hose to the base unit by inserting the other end into the water outlet. While pushing firmly in on the hose, twist the outer collar clockwise until tight to ensure a water-tight connection (Fig. 14).

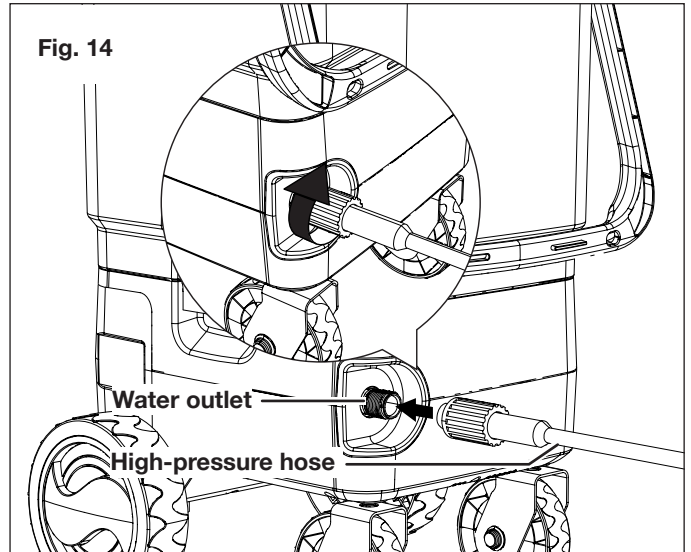

10. Put the trigger gun with spray wand assembly on the gun holder. Your pressure washer is ready for use (Fig. 15).

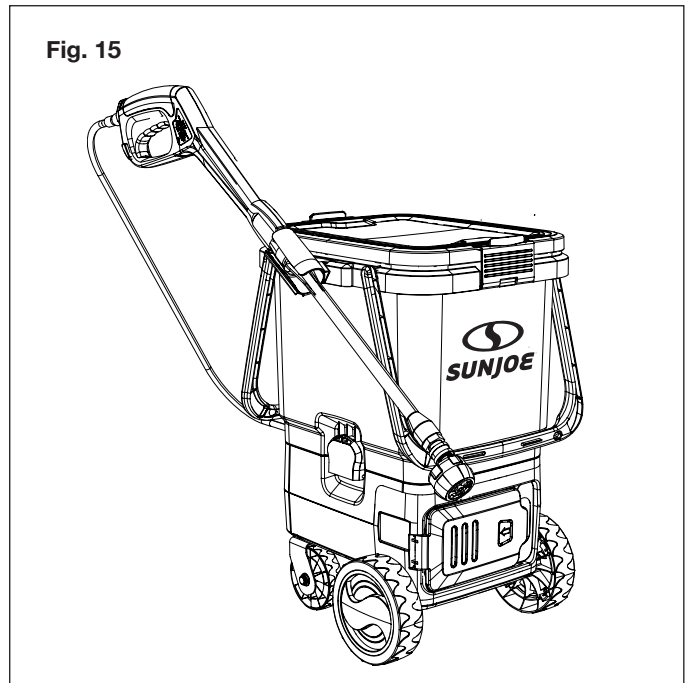

Operation

⚠️ IMPORTANT! This pressure washer is equipped with a micro-switch sensitive to water flow. This Total Stop System (TSS) senses water flow in the pump. When the trigger is released, water stops flowing through the pump. The TSS then automatically turns the motor off to protect the pump from overheating, thus saving energy and prolonging pump life.

The TSS system will work only when there's water in the bucket or the base unit is connected with a water supply. When there's no water connected with the unit, the On/Off button has to be pressed to stop the unit.

⚠️ IMPORTANT! This system is capable of producing 8 Mpa. To avoid rupture and injury, do not operate this pump with components rated less than 8 Mpa working pressure (including but not limited to spray guns, hose, and hose connections).

Connecting to Water Source and Start the Unit

1. Open the battery compartment cover and slide the battery packs in until they click to lock into position, then close the battery compartment cover (Fig. 16).

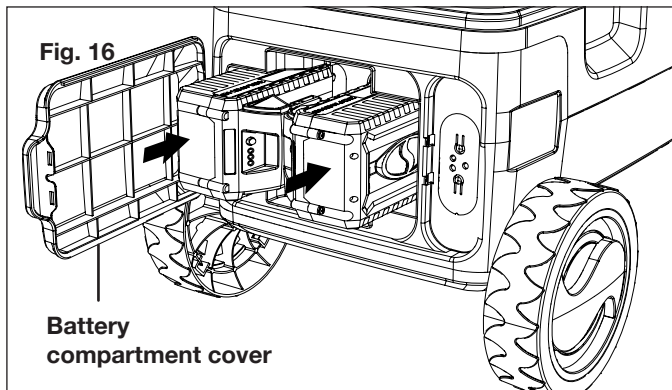

2. Remove the water bucket from the base unit and fill with clean (fresh) water.

⚠️ WARNING! The intake water temperature must not exceed 104°F/40°C.

⚠️ CAUTION! The washer must only be used with clean (fresh) water; use of unfiltered water containing corrosive chemicals will damage the washer.

⚠️ WARNING! Do not fill the bucket with the bucket still fixed on the base unit.

3. Put the bucket back on the base unit. Make sure the bucket is properly aligned on the base. Latch and lock the buckles to ensure the bucket is securely connected before using (Figs. 7 – 8).

NOTE: If you do not want to use the bucket, you can use the base unit directly as a pressure washer. See following instructions (step 4 – 6) to learn how to connect the base unit with a water supply.

4. Disengage the bucket buckles and remove the bucket from the base unit. Disconnect the bucket adapter from the water inlet by turning it counterclockwise with a wrench (Fig. 17).

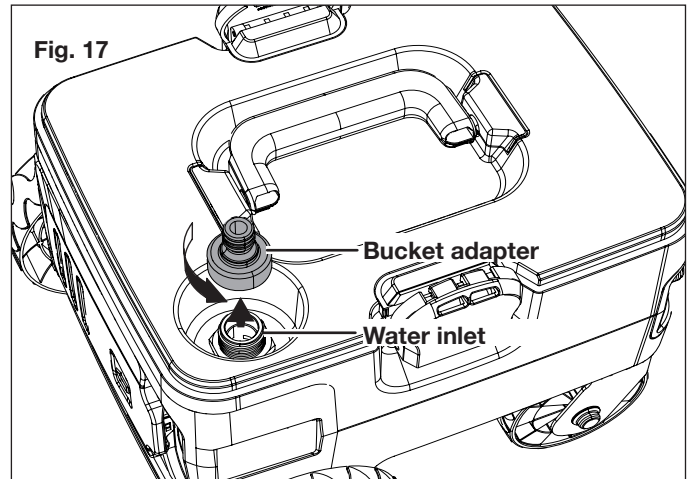

5. Connect the included brass water inlet connector to the water inlet and turn it clockwise to lock securely. Connect the included garden hose adapter with the brass water inlet connector and push it until it clicks and locks in place (Fig. 18).

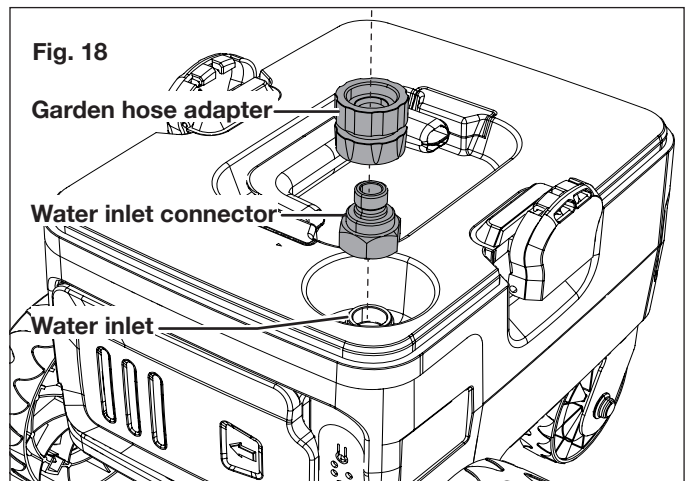

6. Thread your garden hose (male end) into the garden hose adapter (Fig. 19). The garden hose must have an internal diameter of at least 13 mm (1/2 in.) and must be reinforced. The water supply must be at least equal to the washer delivery capacity.

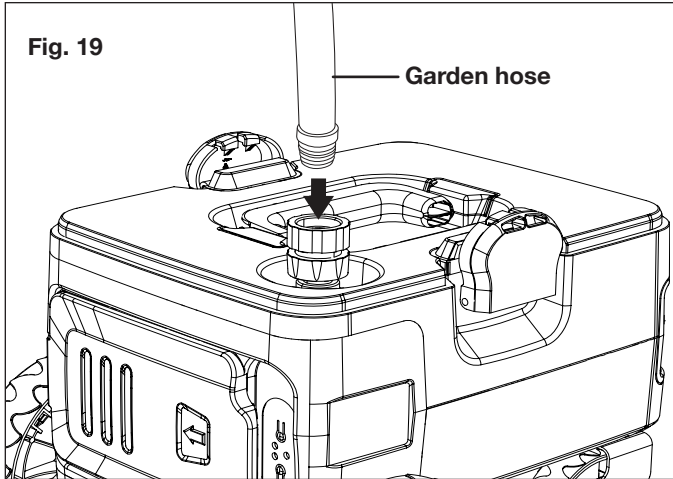

Fig. 19

Garden hose

7. Attach garden hose to water supply (Fig. 20).

WARNING! Water that has flowed through back flow preventers is considered to be non-potable.

WARNING! The water supply must not exceed 0.7Mpa.

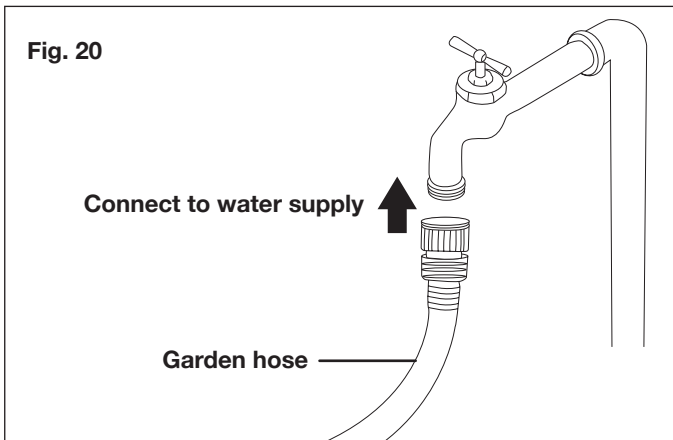

Fig. 20

Connect to water supply

Garden hose

8. If only using the base unit, turn the water supply tap on completely.
9. Push the safety lock on the spray gun handle, then press the trigger for a few seconds until the water flow is steady. Operating the pressure washer in this manner will allow air to escape and discharge residual pressure in the hose (Fig. 21).

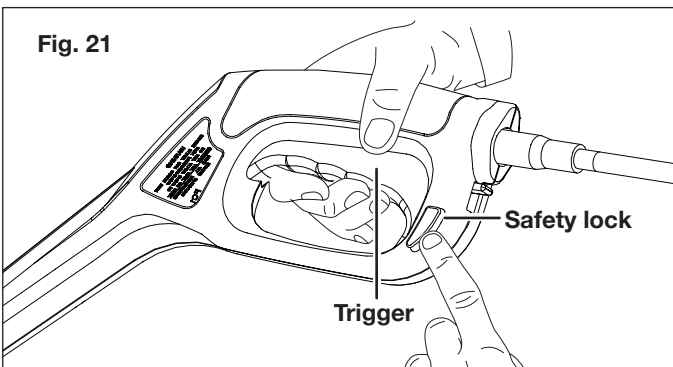



Fig. 21

Safety lock

Trigger

10. Keeping the trigger pressed, turn on the unit by pressing the On/Off button on the control panel. Using the "Pressure Select" feature, you can also use the pressure washer in a lower setting by pressing the  button below the ON/Off button (Fig. 22).

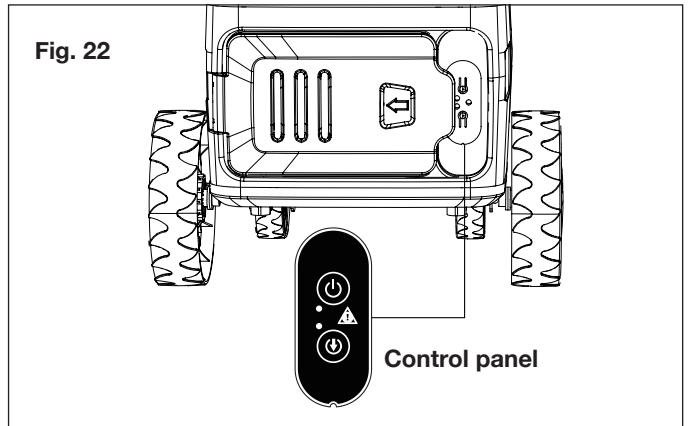

Fig. 22

Control panel

NOTE: This machine is equipped with 2 power/pressure levels. When starting, the machine is set in default high power/high pressure level. See table below for detailed specs.

Power	Light indication	Rated flow	Rated pressure
High	● - On ○ - Off	0.65 GPM	800 PSI
Low	● - On ● - On	0.77 GPM	650 PSI

11. When re-starting the motor, always keep the trigger pressed.

NOTE: The motor only runs when the trigger is operated and shuts off when the trigger is released.

Control Panel (Fig. 23)

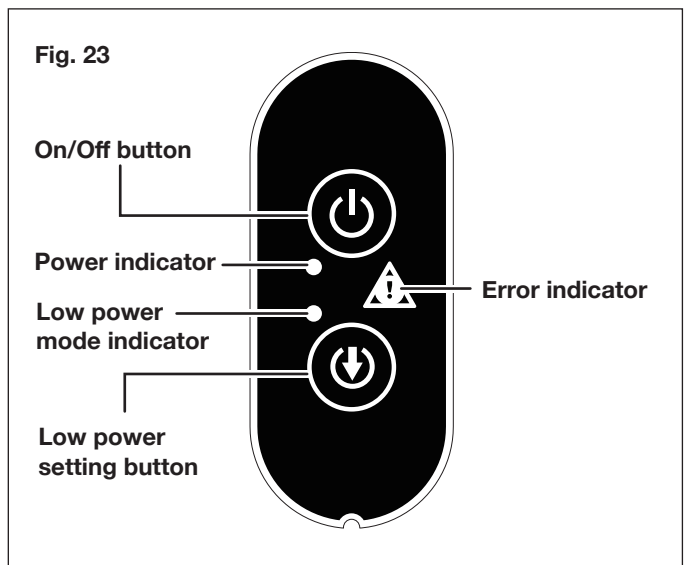

Fig. 23

On/Off button

Power indicator

Low power mode indicator

Low power setting button

Error indicator

- 1. On/Off button** – Press  to turn on and shut off the machine. The power indicator will light when the machine is turned on.
- 2. Low setting button** – After turning on the machine, press to enter the low power/pressure level. The low setting indicator will light when the machine enters low power/pressure level. The low power/pressure level reduces the motor speed for a maximum battery life. It is also ideal for cleaning everyday dirt + grime.

NOTE: The machine is set to be operated in default high power/ high pressure level when it is started every time. You need to press the low setting button if low power/pressure level is desired. To enter HIGH power/high pressure level from low power/pressure level, press the low setting button again. The low setting indicator will turn off and the machine will increase power and pressure.

- 3. Error indicator** – The error indicator is off when the machine is working normally. A flashing error indicator means something is wrong with the machine. Check the table below for possible causes and solutions for the flashing error indicator. If the indicator keeps flashing after all the measures have been taken, please call the Snow Joe® + Sun Joe® customer service center at 1-866-SNOWJOE (1-866-766-9563)

Error Indicator	Possible Reasons	Solutions
Flashes for 6 seconds and shuts down	Short circuit	Please call the Snow Joe® + Sun Joe® customer service center at 1-866-SNOWJOE (1-866-766-9563) for assistance.
Flashes for 3 min and shuts down	<ul style="list-style-type: none"> • Nozzle is blocked. • Batteries are flat. 	<ul style="list-style-type: none"> • Clean the nozzle with the included needle clean-out tool. • Recharge the batteries.

Using the 5-in-1 Quick-connect Nozzle

Before beginning any cleaning task, determine the best spray setting for the job. The included 5-in-1 Quick-Connect nozzle features 5 different spray options to match your desired cleaning application. The nozzle patterns are 40° (for gentle cleaning), 15° (for tough jobs), 0° (for spot cleaning or hard-to-reach areas), 0+ (for long range spray), 40+ (for short range spray).

CAUTION! NEVER change spray pattern without locking the safety lock on the trigger handle.

WARNING! High-pressure jets can be dangerous if subject to misuse. The jet must not be directed at persons, pets, live electrical equipment, or the appliance itself.

To change the spray pattern for the nozzle, first make sure the pressure washer is shut off and not connected with any water source, and the trigger gun is locked, then twist the nozzle collar to align the symbol of the desired spray pattern with the mark on the nozzle (Fig. 24).

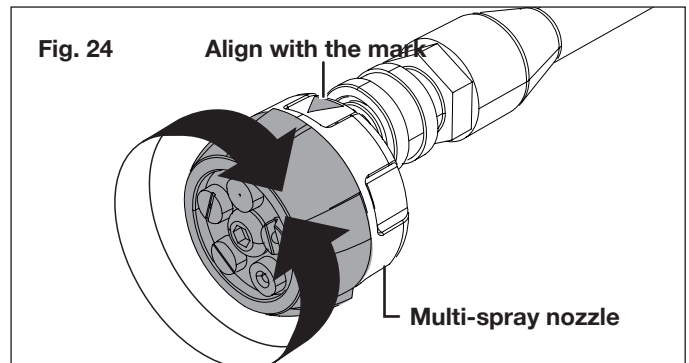

Working with Detergents

When cleaning with the pressure washer, some cleaning tasks can be solved with water alone, but for most tasks cleaning with detergent allows for more effective dirt removal.

WARNING! Use only detergents specifically designed for use with pressure washers, such as Sun Joe® HOUSE + DECK WASH (SPX-HDC1G), Sun Joe® SNOW FOAM AUTO WASH (SPX-FCS1G), or Sun Joe® HEAVY DUTY CLEANER (SPX-APC1G). **DO NOT USE** household detergents, acids, alkaline solutions, bleaches, solvents, flammable material, or industrial grade solutions. These could damage the pressure washer. Many detergents may require mixing prior to use. Prepare the cleaning solution as instructed on the solution bottle.

1. Turn off the pressure washer, remove the bucket or shut off the water supply. Pull the trigger to release water pressure.
2. Remove the spray wand attachment from the trigger gun.
3. Remove the soap dispenser sprayer from the bottle and fill with mixed detergent. Put the sprayer back on when finished.
4. Take the foam cannon and align the two tabs with your trigger gun. Once aligned, push it into the trigger gun, and twist counter-clockwise to lock securely into place (Fig. 25).

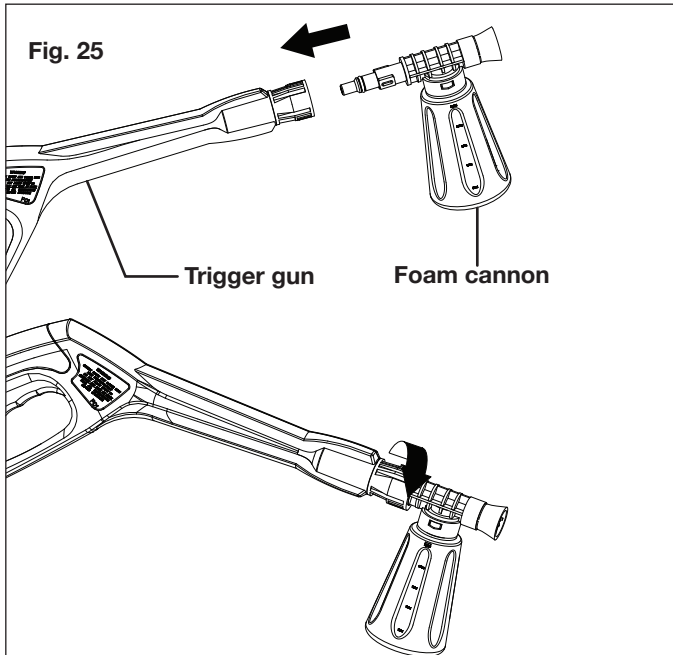

5. Reconnect the pressure washer with the water bucket or the garden hose. Turn on the pressure washer. Pull the trigger to operate the unit.

⚠ CAUTION! Always test the detergent in an inconspicuous area before use.

6. Apply detergent from the bottom to the top of the dry surface to be cleaned.

NOTE: Wetting the surface first is not recommended as it dilutes the detergent and reduces its cleaning ability.
7. Allow the detergent to remain on the surface for a short time before rinsing. Do not allow the detergent to dry on the surface.

⚠ CAUTION! Damage may occur to painted surfaces if the detergent is allowed to dry on the surface. Wash and rinse a small section at a time. Avoid working on hot surfaces or in direct sunlight.

⚠ CAUTION! Failure to follow these cleaning instructions will cause the injection system to become clogged and inoperable.

Rinsing with the Pressure Washer

1. Turn off the pressure washer, remove the bucket or shut off the water supply.
2. Pull the trigger to release water pressure.
3. Push the safety lock on the trigger handle to lock it.
4. Remove the foam cannon by pushing firmly in while twisting it clockwise to unlock the tabs and remove from the slots. Pull the attachment out of the trigger gun.

5. Attach the spray wand and the 5-in-1 nozzle onto the trigger gun.
6. Select the right spray pattern for the job (Fig. 26).

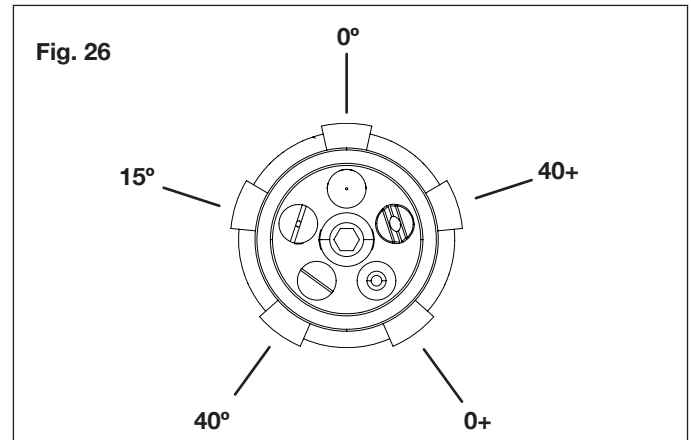

- I) The 0° intense-jet spray pattern is an extremely powerful, high-pressure, pencil-point jet stream. It is used to cut heavy dirt deposits in a small, concentrated area. It is ideal for dissolving stubborn substances, like tar and grease spots on concrete, or for removing caked mud from equipment. Use this pattern to clean hard-to-reach areas including the facades of 2-story buildings or the undersides of lawn mowers and tractors.

NOTE: Care should be used when choosing the right spray pattern to avoid permanently gouging wood or damaging fragile surfaces.
 - II) Use the 0+ straight line pattern for home siding, brick patios, wood decks, driveways, or sidewalks. When using this nozzle, test a small area first to avoid surface damage.
 - III) Use the 15° spray pattern for intense cleaning jobs on hard surfaces. Applications include stripping paint, removing oil stains, grease, heavy mildew stains, and rust from steel. This spray should only be used in areas that can withstand the high-pressure from this spray.
 - IV) Use the 40° wide-spray pattern to clean items such as cars, trucks, boats, patio furniture, or lawn equipment.
 - V) Use the 40+ pattern for light cleaning applications.
7. Lock the bucket with water on the base unit or connect the base unit with a water supply. Start at the top of the area to be rinsed and work your way down, making sure to overlap your strokes.

⚠ IMPORTANT! NEVER USE:

- Bleach, chlorine products, and other corrosive chemicals
- Liquids containing solvents (e.g. paint thinners, gasoline, oils)
- Tri-sodium phosphate products
- Ammonia products
- Acid-based products

These chemicals will harm the unit and will damage the cleaning surface.

Shutting Down

1. Press the On/Off button on the control panel.
2. Pour the remaining water out from the bucket or turn off the water source.
3. Hold the trigger to release water pressure.
4. If using the base unit directly, disconnect the garden hose from the water inlet on the base unit.
5. Disconnect the high-pressure hose connection on the trigger gun handle.
6. Release the trigger and lock the gun safety lock.

⚠️ WARNING! Turn off the water supply and squeeze the trigger to depressurize the unit. Failure to do so could result in personal injury due to discharge of high-pressure water.

Taking a Break

If you are taking a break between cleaning tasks:

1. Lock the gun safety lock.
2. Push the On/Off button to stop the machine.

NOTE: If being kept in stand-by mode for 3 minutes, the machine will shut off automatically.

Storage

⚠️ CAUTION! Always store your pressure washer in a location where the temperature will not fall below 32°F (0°C). The pump in this machine is susceptible to permanent damage if it freezes. **FREEZE DAMAGE IS NOT COVERED BY THE WARRANTY.**

- Store the pressure washer indoors in a dry, covered area where it is not subject to adverse weather conditions.
- It is important to store this product in a frost-free area.
- Always empty water from all hoses, the pump, the soap dispense attachment and the bucket before storing.

⚠️ CAUTION! The use of a pump protector is recommended to prevent cold weather damage during storage over the winter months.

Winterizing + Long-Term Storage

If you must store your pressure washer in a location where the temperature falls below 32°F (0°C), you can minimize the chance of damage to your machine by utilizing the following procedure:

- Disconnect all water connections.
- Turn on the machine for a few seconds until the remaining water in the pump exits. Turn off immediately.

- Do not allow the high-pressure hose to become kinked.
- Store the machine and accessories in a room that does not reach freezing temperatures.
- Do not store near a furnace or other sources of heat that may dry out the pump seals.
- Operate the pressure washer with non-corrosive/non-toxic anti-freeze, a pump saver, or a pump protector before storing for the winter.

⚠️ WARNING! Before reusing, completely flush the unit out with clear water. Anti-freeze products can damage paintwork, so you must ensure there is no anti-freeze left in the system before using it again.

Maintenance

⚠️ CAUTION! Before working on the pressure washer, remove the batteries from the compartment.

1. To ensure good performance, check and clean the filters. Remove the filters and rinse with warm water to prevent any foreign matter from clogging the pump.
2. Remove the water bucket lid and make sure the bucket is empty.
3. Turn the bucket filter counterclockwise to align the tabs with the slots, and disassemble it from the water bucket (Fig. 27).

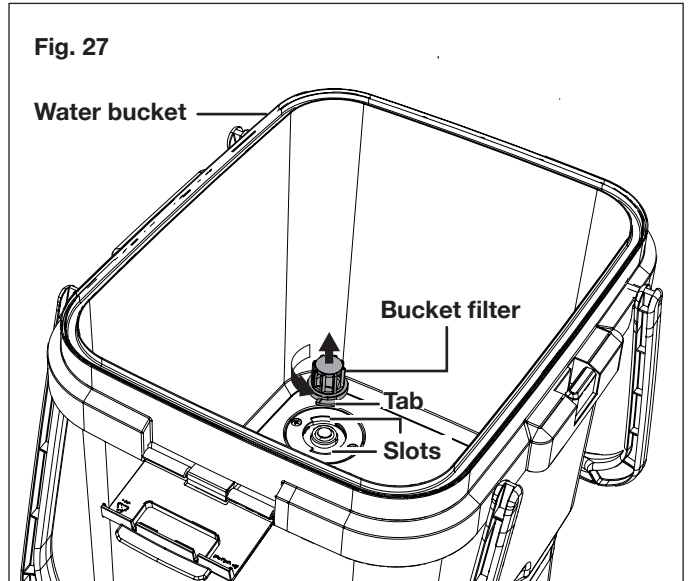

4. Remove the bucket from the base unit. Disconnect the bucket adapter from the water inlet by turning it counterclockwise (Fig. 17)
5. Using pliers, remove the water inlet filter from the water inlet (Fig. 28)

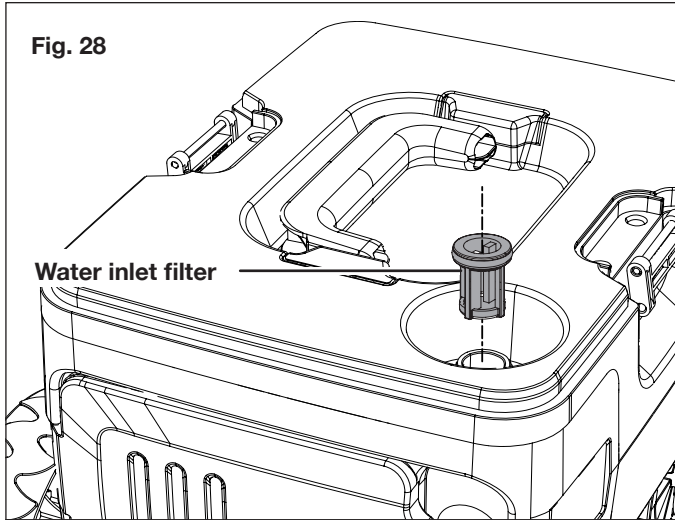

6. Rinse both filters and all other components with warm water to prevent any foreign matter from clogging the pump.
7. Remove the nozzle by placing your hand over the nozzle while pulling back on the Quick-Connect collar. Clean the nozzle with the needle clean-out tool provided (Fig. 29). Remove the spray wand from the gun; remove any dirt from the nozzle orifices and rinse.

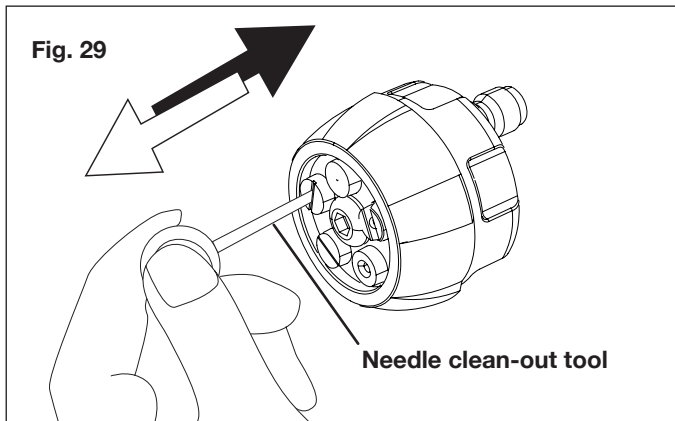

8. Remove additional debris by back flushing water through the nozzle and spray wand. To do this, place the end of your garden hose (with water running) to the tip of the nozzle, pushing water and debris out of the back opening of the nozzle and spray wand.

Disposal

Recycling the Washer

- Do not dispose of electrical appliances as unsorted municipal waste. Use separate collection facilities.
- Contact your local government agency for information regarding the collection systems available.
- If electrical appliances are disposed of in landfills or dumps, hazardous substances can leak into the groundwater and get into the food chain, damaging your health and well-being.

- When replacing old appliances with new ones, the retailer is legally obligated to take back your old appliance for disposal at least free of charge.

Recycling + Disposal

The product comes in a package that protects it against damage during shipping. Keep the package until you are sure that all parts have been delivered and the product is functioning properly. Recycle the package afterwards or keep it for long-term storage.



WEEE symbol. Waste electrical products should not be disposed of with household waste. Please recycle where facilities exist. Check with your local authority or local store for recycling regulations.

Battery Caution + Disposal

Always dispose of your battery packs according to federal, state, and local regulations. Contact a recycling agency in your area for recycling locations.

CAUTION! Even discharged battery packs contain some energy. Before disposing, use electrical tape to cover the terminals to prevent the battery pack from shorting, which could cause a fire or explosion.

WARNING! To reduce the risk of injury or explosion, never burn or incinerate a battery pack even if it is damaged, dead or completely discharged. When burned, toxic fumes and materials are emitted into the surrounding atmosphere.

1. Batteries vary according to device. Consult your manual for specific information.
2. Install only new batteries of the same type in your product (where applicable).
3. Failure to insert batteries in the correct polarity, as indicated in the battery compartment or manual, may shorten the life of the batteries or cause batteries to leak.
4. Do not mix old and new batteries.
5. Do not mix Alkaline, Standard (Carbon-Zinc) or Rechargeable (Nickel Cadmium, Nickel Metal Hydride, or Lithium-Ion) batteries.
6. Do not dispose of batteries in fire.
7. Batteries should be recycled or disposed of as per state and local guidelines.

Service + Support

If your Sun Joe® 24V-X2-PW1200-CT-RM cordless pressure washer requires service or maintenance, please call the Snow Joe® + Sun Joe® customer service center at 1-866-SNOWJOE (1-866-766-9563).

Model + Serial Numbers

When contacting the company, reordering parts, or arranging service from an authorized dealer, you will need to provide the model and serial numbers, which can be found on the decal located on the housing of the unit. Copy these numbers into the space provided below.

Record the following numbers from the housing or handle of your new product:

Model #:
| 2 | 4 | V | - | X | 2 | - | P | W | 1 | 2 | 0 | 0 | - | C | T | - | R | M |

Serial #:
| | | | | | | | | | | | | | | | | | | | | | | | | | | |



Troubleshooting

- Remove the batteries from the compartment before carrying out maintenance on the machine or when checking that its parts are in proper working order.
- To avoid unnecessary hassles, consult the following table before contacting customer service with any mechanical issues.

Problems	Possible Cause	Possible Solution
Machine refuses to start	<ul style="list-style-type: none"> • Power failure/Batteries are not inserted well 	<ul style="list-style-type: none"> • Check to make sure the batteries have sufficient power and are inserted well
Fluctuating pressure	<ul style="list-style-type: none"> • Pump sucking air • Valves dirty, worn out, or stuck • Pump seals worn out 	<ul style="list-style-type: none"> • Check the hoses and connections are airtight • Clean or replace valves/seals • Please call the Snow Joe® + Sun Joe® customer service center at 1-866-SNOWJOE (1-866-766-9563) for assistance
The error indicator flashes and then machine stops	<ul style="list-style-type: none"> • Nozzle partially blocked • Batteries are flat 	<ul style="list-style-type: none"> • Clean the nozzle • Charge the batteries.
Machine pulsating	<ul style="list-style-type: none"> • Air in inlet hose • Inadequate supply of mains water • Nozzle partially blocked • Water filter blocked • Hose kinked 	<ul style="list-style-type: none"> • Allow machine to run by holding the trigger until regular working pressure resumes • Check that the water supply corresponds to the specifications required • WARNING! Avoid using long, thin hoses (minimum 1/2 in. diameter) • Clean the nozzle • Clean the filters • Straighten out the hose to remove any kinks/blockages
Machine often starts and stops by itself	<ul style="list-style-type: none"> • Pump/spray gun is leaking • Trigger mechanism is broken 	<ul style="list-style-type: none"> • Please call Snow Joe® + Sun Joe® customer service center at 1-866-SNOWJOE (1-866-766-9563) for assistance
Machine starts, but no water comes out	<ul style="list-style-type: none"> • Pump/hoses or accessories frozen • No water supply • Water filter blocked • Nozzle blocked 	<ul style="list-style-type: none"> • Wait for pump/hoses or accessories to thaw • Connect inlet water • Clean the filters • Clean the nozzle

Optional Accessories

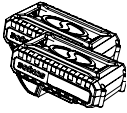
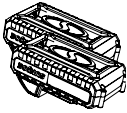
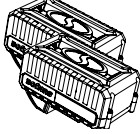
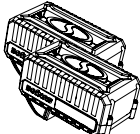
⚠️ WARNING! ALWAYS use only authorized Snow Joe® + Sun Joe® replacement parts and accessories. NEVER use replacement parts or accessories that are not intended for use with this cordless pressure washer. Contact Snow Joe® + Sun Joe® if you are unsure whether it is safe to use a particular replacement part or accessory with your pressure washer. The use of any other attachment or accessory can be dangerous and could cause injury or mechanical damage.

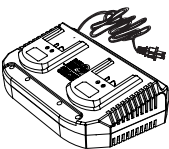
Accessories	Item	Model
	iON+ 24V 2.0 Ah Lithium-Ion Battery <i>Battery Runtime Max: Low setting – 12 min</i> <i>High setting – 8 min</i>	24VBAT-LTE
	iON+ 24V 2.5 Ah Lithium-Ion Battery <i>Battery Runtime Max: Low setting – 13 min</i> <i>High setting – 10 min</i>	24VBAT-LT
	iON+ 24V 4.0 Ah Lithium-Ion Battery <i>Battery Runtime Max: Low setting – 20 min</i> <i>High setting – 17 min</i>	24VBAT
	iON+ 24V 5.0 Ah Lithium-Ion Battery <i>Battery Runtime Max: Low setting – 26 min</i> <i>High setting – 21 min</i>	24VBAT-XR
	iON+ 24V Lithium-Ion Battery Quick Charger	24VCHRG-QC
	iON+ 24V Lithium-Ion Dual-Port Battery Charger	24VCHRG-DPC

Sun Joe’s complete line of premium pressure washer accessories and attachments make it easy to get your dirty work done, and also help you get the most out of your model!

SHOP ONLINE now at sunjoe.com

NOTE: Accessories are subject to change without any obligation on the part of Snow Joe® + Sun Joe® to provide notice of such changes. Accessories can be ordered online at sunjoe.com or via phone by contacting the Snow Joe® + Sun Joe® customer service center at 1-866-SNOWJOE (1-866-766-9563).



SNOW JOE® + SUN JOE® REFURBISHED GOODS WARRANTY

GENERAL CONDITIONS:

Snow Joe® + Sun Joe® operating under Snow Joe®, LLC warrants this refurbished product to the original purchaser for 90 days against defects in material or workmanship when used for normal residential purposes. If a replacement part or product is needed, it will be sent free of charge to the original purchaser except as noted below.

The duration of this warranty applies only if the product is put to personal use around the household. It is the owner's responsibility to correctly perform all maintenance and minor adjustments explained in the owner's manual.

HOW TO OBTAIN YOUR REPLACEMENT PART OR PRODUCT:

To obtain a replacement part or product, please visit snowjoe.com/help or email us at help@snowjoe.com for instructions. Please be sure to register your unit beforehand to speed up this process. Certain products may require a serial number, typically found on the decal affixed to the housing or guard of your product. All products require a valid proof of purchase.

EXCLUSIONS:

- Wearing parts like belts, augers, chains and tines are not covered under this warranty. Wearing parts can be purchased at snowjoe.com or by calling 1-866-SNOWJOE (1-866-766-9563).
- Batteries are covered in full for 90-days from the date of purchase.

Snow Joe® + Sun Joe® may from time to time change the design of its products. Nothing contained in this warranty shall be construed as obligating Snow Joe® + Sun Joe® to incorporate such design changes into previously manufactured products, nor shall such changes be construed as an admission that previous designs were defective.

This warranty is intended to cover product defects only. Snow Joe®, LLC is not liable for indirect, incidental or consequential damages in connection with the use or misuse of the Snow Joe® + Sun Joe® products covered by this warranty. This warranty does not cover any cost or expense incurred by the purchaser in providing substitute equipment or service during reasonable periods of malfunction or non-use of this product while waiting for a replacement part or unit under this warranty. Some states do not allow exclusions of incidental or consequential damages so the above exclusions may not apply in all states. This warranty may give you specific legal rights in your state.

HOW TO REACH US:

We're here to help Monday through Friday from 9AM to 7PM EST and Saturday and Sunday 9AM to 4PM. You can reach us at 1-866-SNOWJOE (1 866-766-9563), online at snowjoe.com, via email at help@snowjoe.com or tweet us @snowjoe.

EXPORTS:

Customers who have purchased Snow Joe® + Sun Joe® products exported from the United States and Canada should contact their Snow Joe® + Sun Joe® distributor (dealer) to obtain information applicable to your country, province or state. If for any reason, you are not satisfied with the distributor's service, or if you have difficulty obtaining warranty information, contact your Snow Joe® + Sun Joe® seller. If in the event your efforts are unsatisfactory, please reach out to us directly.



sunjoe.com